

tissin

Volume Booster

TS100 Series

Instruction Manual



TS100 VOLUME BOOSTER
MODEL
SERIAL No.
MAX. SUP. PRESS 1.0 MPa
MAX. SIG / OUT. PRESS 0.7MPa
Made in Korea **tissin** www.tissin.co.kr



Ver. PM-TS100EN_11/2018

Description

Volume Booster TS100 is one-to-one Signal to output Supply Air, when used with a positioner/actuator, it is a control device to increase the stroking speed of control valves.

Features

- Precise and fast response.
- Adjustable Sensitivity control allows this Volume Booster to meet various control valve requirements.
- Soft seats provide tight shut off to reduce unnecessary air consumption.
- Small size and light weight allow the Volume Booster to be installed directly inline without a bracket.
- Options available (High and Low Temperature)

Warranty

- This product has been fully inspected and shipped through a thorough quality inspection procedure. The manufacturer warranty period of the product is 18 months after the product is shipped from Tissin in Korea.
- For any failure or damage reported within the warranty period which is clearly our responsibility, a replacement product or necessary parts will be provided. This limited warranty applies only to our product independently, and not to any other damage incurred due to the failure of the product.
- Using the device in a manner that does not fall within the scope of its intended use, disregarding this manual, using under qualified personnel, or making unauthorized alterations releases the manufacturer from liability for any resulting damage. This renders the manufacturer's warranty null and void.



Precautions

General Information

- Please ensure to read and understand the manual before installation and maintenance of the products.
- The manual should be passed to the End-User.
- When the product is not used within its description range, it may cause the product to malfunction so please follow the product manual instructions.
- The manual may be modified by us without any prior notice. When you require the latest information, please visit our website <http://www.tissin.co.kr>.

Handling Precautions

- Do not install, operate or maintain without being fully trained and qualified in Valve and accessory installation.
- When exceeding the permitted air pressure range, it may cause injury or property damage due to compressed air explosion. So it is very important to carefully read, understand and follow all of the contents of the relevant product manual.
- To avoid the inflow of the excessive air to the actuator, it is highly recommended to install an air filter regulator in front of the Volume Booster.

User Environment

- Do not use in corrosive environments.
- When used in environments that are a higher temperature than the specified temperature range, it may cause a lower life cycle of the product. So please ensure to use within the specified temperature range. (Refer to Page 3)

Specification

Model	TS100	
Max Supply Pressure	1Mpa	
Signal Pressure	0.14~0.7Mpa	
Signal to Output Ratio	1:1	
Linearity	1%	
Flow Capacity (CV)	Supply	1.32
	Exhaust	1.19
Signal Port	PT(NPT)1/4	
Input / Output Port	PT(NPT)1/4	
Temperature Limits	-20~70°C(Standard)	
Material	Aluminum Die-Casting	
Weight	1.3kg	

Materials of Construction

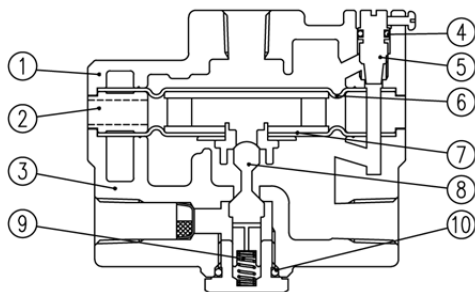

NO.	TITLE	MATERIAL
1	COVER	ALDC12
2	RING EXHAUST	ALDC12
3	BODY	ALDC12
4	O-RING	NBR
5	ADJUST SCREW	STS
6	DIAPHRAGM UPPER	NBR
7	ASS'Y DIAPHRAGM	AL / NBR
8	POPPET	STS
9	SPRING SEAT	STS
10	O-RING	NBR

Principle of Operation

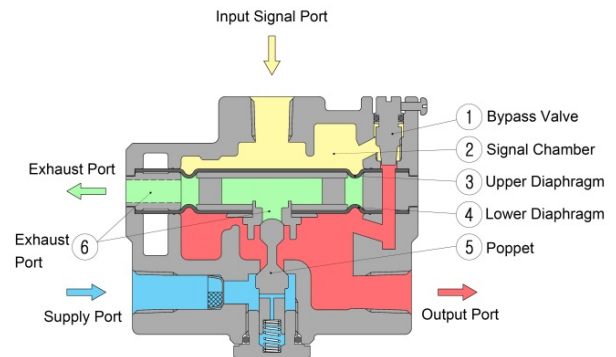

<Sectional View >

When the Input Signal to Supply Air to the actuator increases, Supply Air of Signal Chamber (2) and the pressure of the Upper Diaphragm (3) increase. The differential pressure at the Lower Diaphragm (4) causes the poppet to move downward and open, providing Supply Air through the Poppet (5) Lower seat line and Output Port to the Actuator.

In contrast, when the Input Signal to Supply Air to the actuator decreases, it causes the Poppet Upper seat to open. The Supply Air in the actuator is released via the Exhaust Port (6).

When the Input Signal Air and Output Supply Air are equalized at 1:1 ratio, the Poppet will move to the original position and block upper and lower seats to keep the current position of the Output Supply Air.

The Bypass Valve (1) is used to adjust the response of the pneumatic volume booster to match the closed control loop safety. The Sensitivity of Output Supply Air to Input Signal can be adjusted by controlling Bypass Valve.

Product Number

Model	TS100		
Air Connection	PT1/4	P	
	NPT1/4	N	
Ambient Temperature	-20℃~70℃		S
	-20℃~120℃		H
	-40℃~70℃		L

Name Plate



MODEL

Indicates the model number.

SERIAL NO.

Indicates the Serial No.

MAX.SUP.PRESS 1.0MPa

Indicates Max. Supply Air Pressure

MAX.SIG/OUT.PRESS 0.7MPa

Indicates Max. Signal & Output Air Pressure

Pneumatic connection

- ① Connect the Positioner's Output Port with the Volume Booster's Signal Port.
- ② Connect the Volume Booster's Output Port with the Actuator.
- ③ Connect the supply air to the Supply Port and install an adequate size Air Filter Regulator that guarantee the Volume Booster's Output Supply Air pressure.

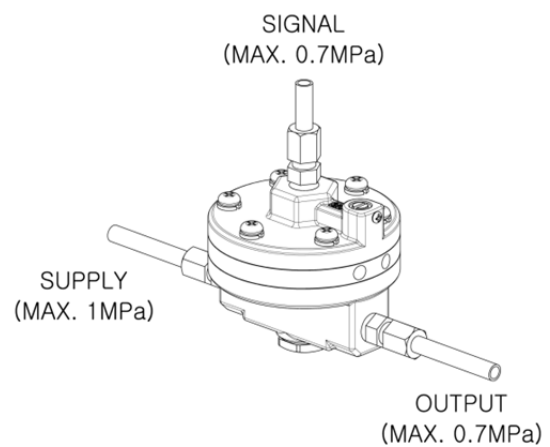

Bracket Installation

If you need to install brackets, you can referring to product dimension drawing make the bracket, and install it as below.

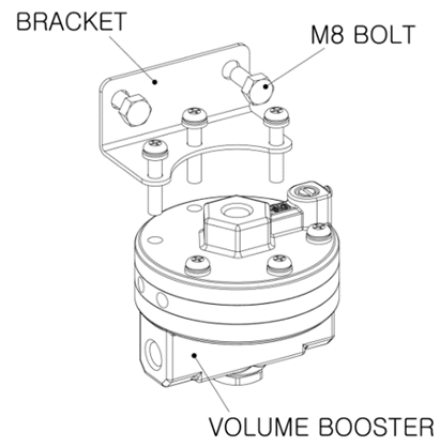

Installation Example

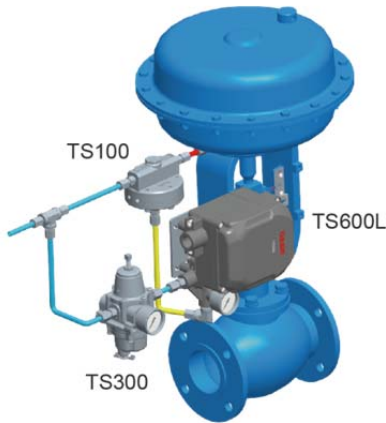

<Single Acting Linear Actuator>

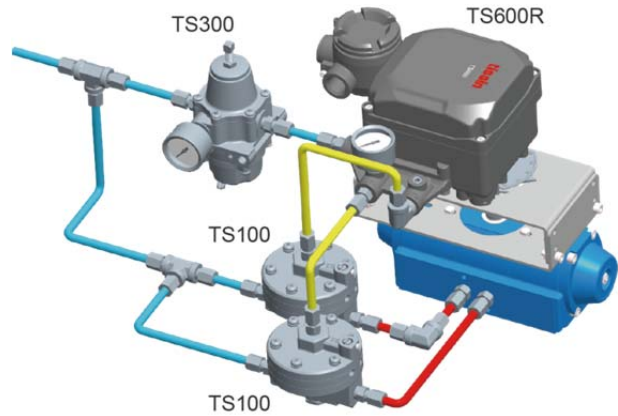

<Double Acting Rotary Actuator>

Dimension (Unit:mm)

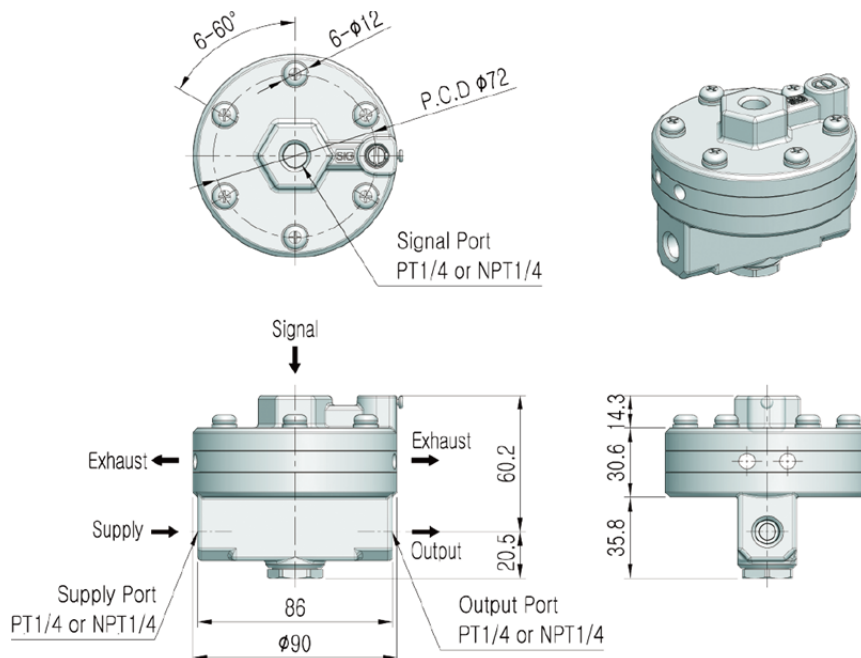



Tissin Co.,Ltd.

201-1105 No 397,Seokcheon-ro,Ojeong-gu,

Bucheon-Si, Gyeonggi-do, Korea

Tel : +82-32-624-4573, Fax : +82-32-624-4574

www.tissin.co.kr